



UNIVERSAL CLIP

HYBRID

8-18

**COBRA** GLOBAL
DECKING
SYSTEM
FASTENER®



CLIP HYBRID 8-18

The benefits

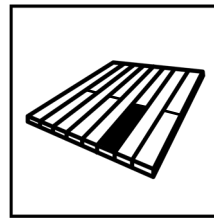

Can be dismantled locally

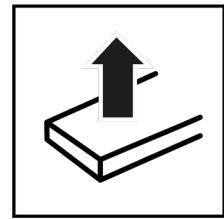

High tensile strength

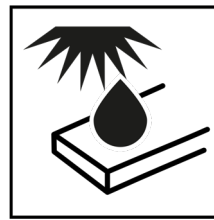

Absorbs wood composite movement

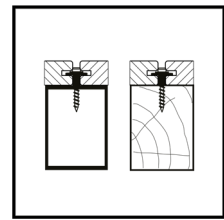

Fixing on wood and aluminium joists

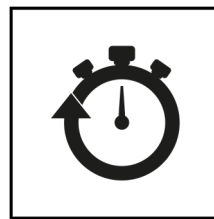

Quick and easy to fit

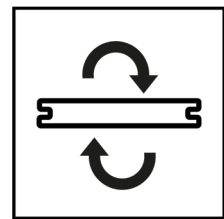

Compatible with reversible blades (from 20 to 26 mm x 150 mm max.)

HYBRID 8-18, A BI-MATERIAL CLIP

Exclusive & Innovative

Claw clip: 6 claws, 3 on each side to firmly hold the blade.

Factory-fitted **stainless steel screws** on the clip for quick and easy installation. Torx grip for comfort and precision

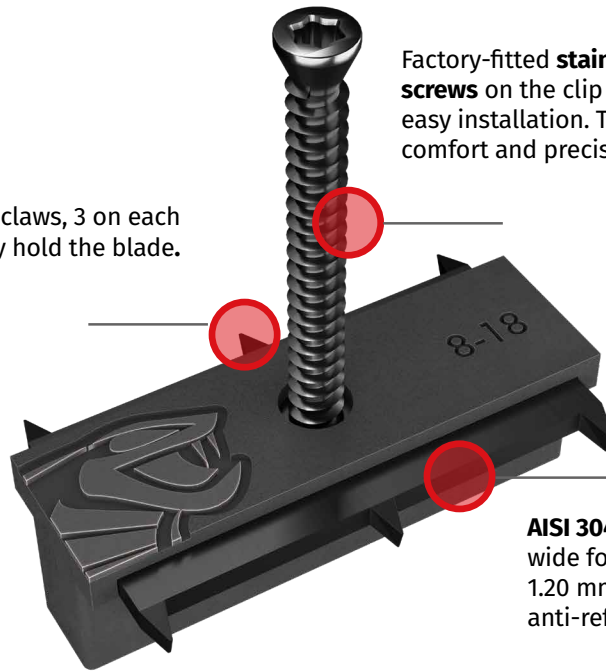

AISI 304 stainless steel fin, 30 mm wide for optimum support and 1.20 mm thick, with matt black anti-reflective lacquer finish



CERTIFIED
22 160 820.1



Honeycomb structure absorbs the movements of the wood composite

Black UV-resistant **polypropylene body**, 6mm wide, ensuring an appropriate and consistent spacing between the blades

Self-drilling point for fixing in wood or aluminium

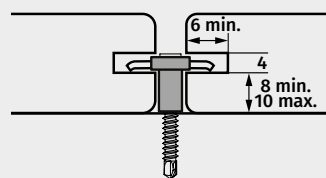
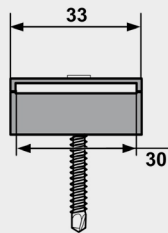
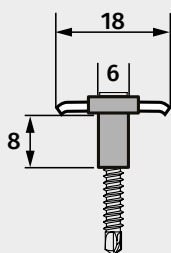
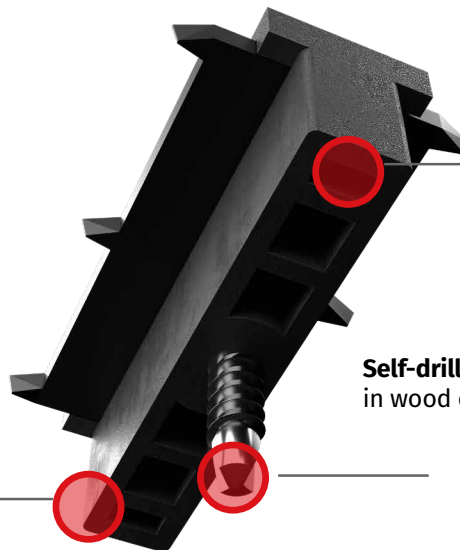

ALUMINIUM



Min thickness
2mm

WOOD

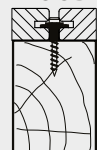

Density max
800 kg/m³

COBRA® HYBRID 8-18

Ideal for installation
composite decking



Inox AISI410

HYBRID 8-18 S AND M CLIP SCREWS

Screw characteristics

- AISI410 stainless steel screws 4.2 x 27 mm size S and 35 mm size M
- Borrow Torx TX15
- Self-drilling tip
- Drilling capacity in aluminium: 3 mm
- Drilling in hardwood with a density of up to 800 kg/m³
- Reduced 6 mm diameter head
- Black lacquer

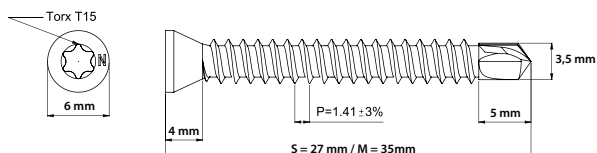

Inox AISI410

HYBRID CLIP SCREWS 8-18 L

Screw characteristics

- 4.8 x 43 mm AISI410 stainless steel screws
- Borrow Torx TX20
- Self-drilling tip
- Drilling capacity in aluminium: 4 mm
- Drilling in hardwood with a density of up to 900 kg/m³
- Reduced 6 mm diameter head
- Black lacquer

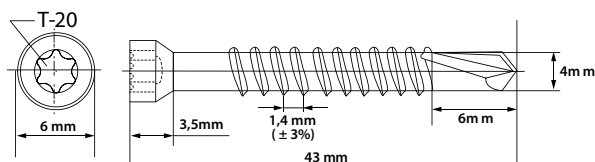



AIRSPACER

Installation & benefits

Cobra Airspacer **promotes ventilation** between the board and the joist without affecting the action of the fixing clip or the movement of the wood.

Its customised design fits perfectly under the honeycomb base of the Cobra Hybrid clips for quick and easy installation.

The Airspacer shim helps to limit the shearing effect on the fixing screw.



Code FR	Code NL	Code EAN	Qty/package	Weight (kg)
1040	2619	3700421810406	8	0,75

CLIP HYBRID 8-18

Installation

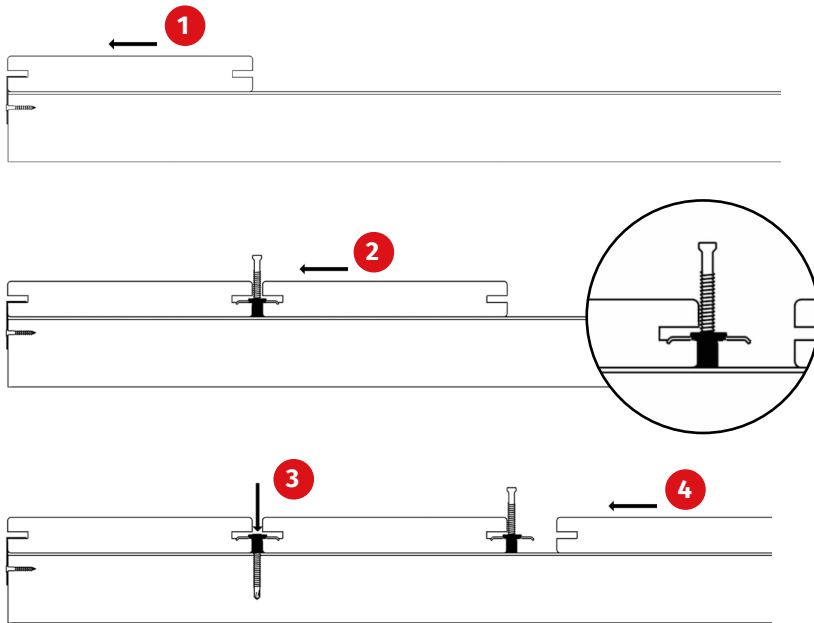

1. Fitting the Start/End clip, then laying the first board

2. Fit the Hybrid clip, claw side down, into the groove, then fit the next board, curved side down, up to the clip wedge.

3. Screw on the clip, holding the blade in place. Tap the blade with a mallet to ensure it is correctly inserted.

4. Repeat the operation until you reach the last blade and finish with the final start/end clip.



The use of clamps is recommended for optimal and rapid screwing of Hybrid clips.

Installation rules

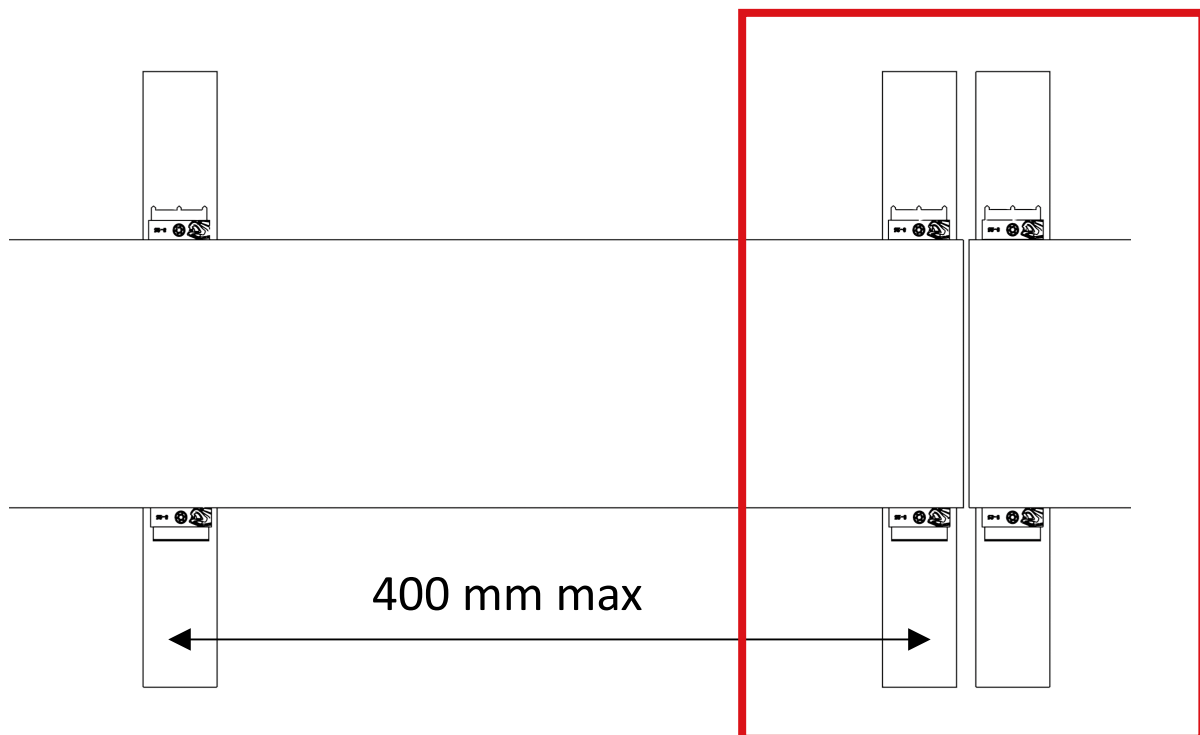

Double jointing at the ends of the boards

Replacing a blade

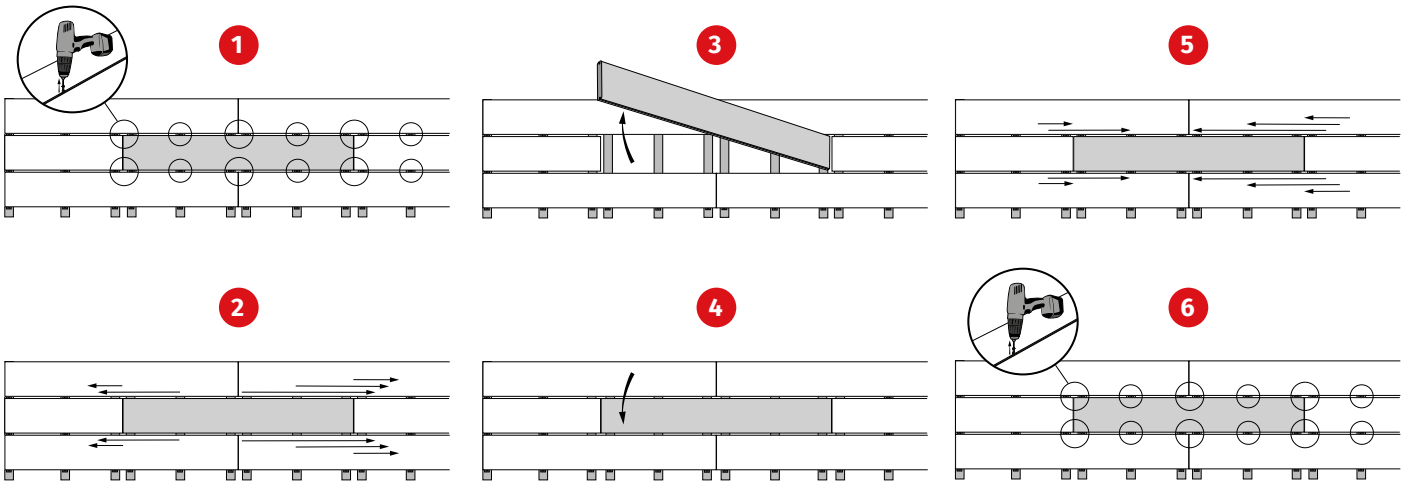

1. Unscrew the clips

2. SPREAD THE CLIPS AT THE ENDS

3. Remove the old blade

4. Place the new blade

5. Replace the clips

6. Screw on the new blade

Packaging

± 3,2 m^{2*}

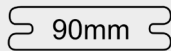

± 4,5 m^{2*}

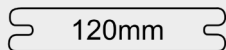

± 5 m^{2*}

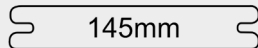

± 8,5 m^{2*}

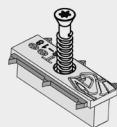
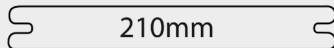

90 pcs

T 15



1 pc

*Rating with a 40mm centre to centre joists distance

Sizes	Code FR	Code NL	Code EAN	Qty/ package	Qty/pallet	Weight (kg)
8-18 S	FR1989	NL2918	3700421819898	8	640	0,88
8-18 M	FR0993	NL2174	3700421809936	8	640	0,88
8-18 L	FR1987	NL 2919	3700421819874	8	640	0,88